

Be-Flow

Product guide

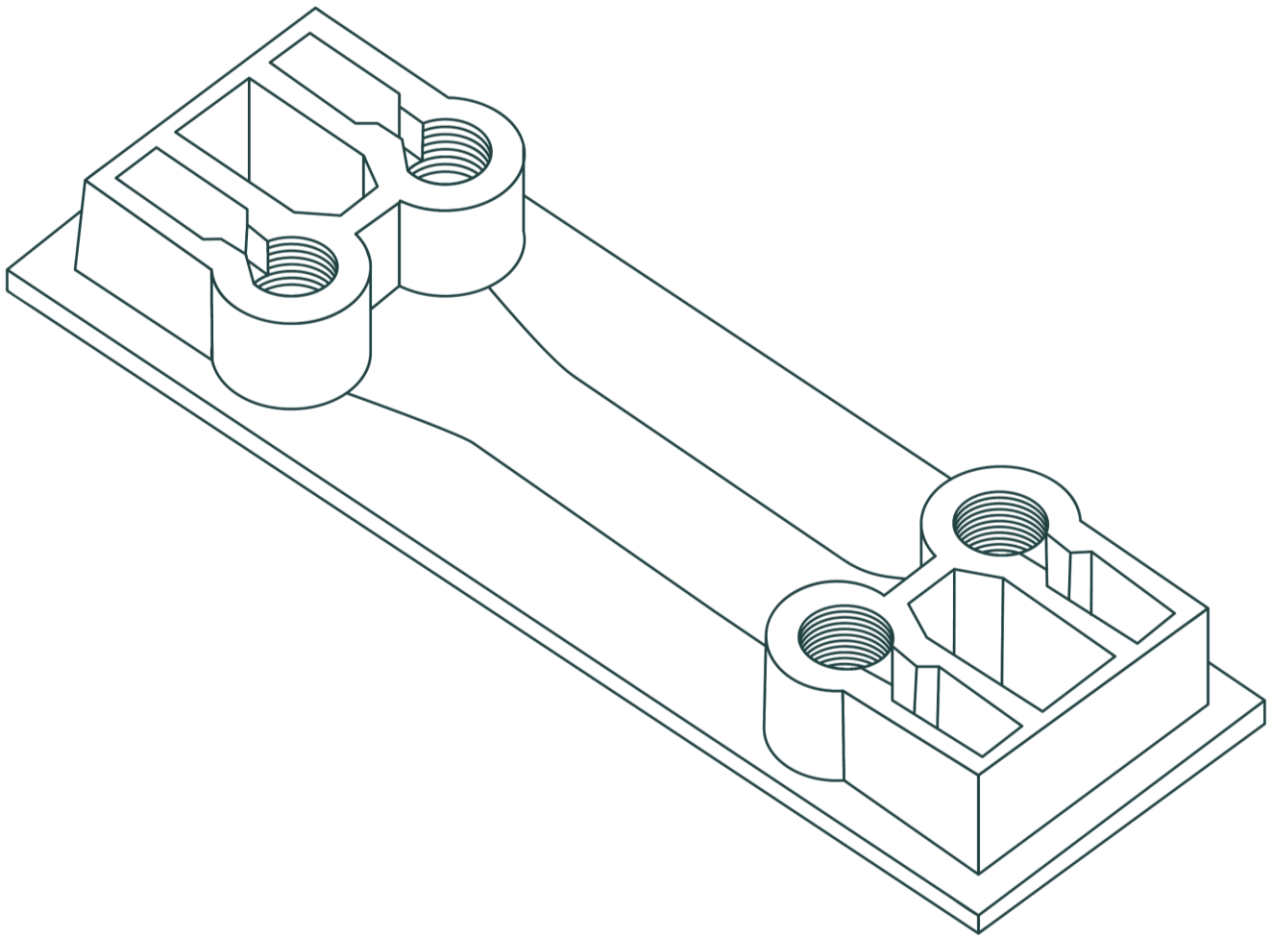

Table of contents

About Be-Flow	3
Technical features.....	4
Content.....	5
Filling and handling.....	6
Coating	7
Cell culture	10
Flow set up.....	12
Culture models.....	13
Contact and support	14

About Be-Flow

This is our most easy to use device dedicated to cell culture under flow. It allows the performance of long term cell culture in two independent channels. Be-Flow is compatible with any microfluidic pump system and can be used simply with a rocker, thanks to its fluid reservoirs situated by the inlets/outlets. This is an optimal device for vascular research where shear stress plays a major role in gene expression.

Technical features

The design of the Be-flow consists of **2 independent channels with screw-like inlet and outlet wells** that allow joining with connectors and tubes to a fluidic system. It is possible to apply an independent flowrate in both channels connecting any perfusion system with the chip using our patented inlet/outlets that avoid the entrance of bubbles to the channel. Evaporation reservoirs are next to the medium reservoirs to be filled with PBS/water during the incubation before closing the system with tubes.

	Height	Width	Length	Total volume
Channel	375 μm	1,5 mm	43 mm	28,5 μL
Inlet/Outlet	7 mm	UNF 1/4" - 28		130 μL
Medium reservoir	5 mm	3,6 mm	8,8 mm	185 μL

* The volumes presented in the table are theoretical values calculated for the standard products. Changes in the device features of custom chips may modify the exact channel volume.

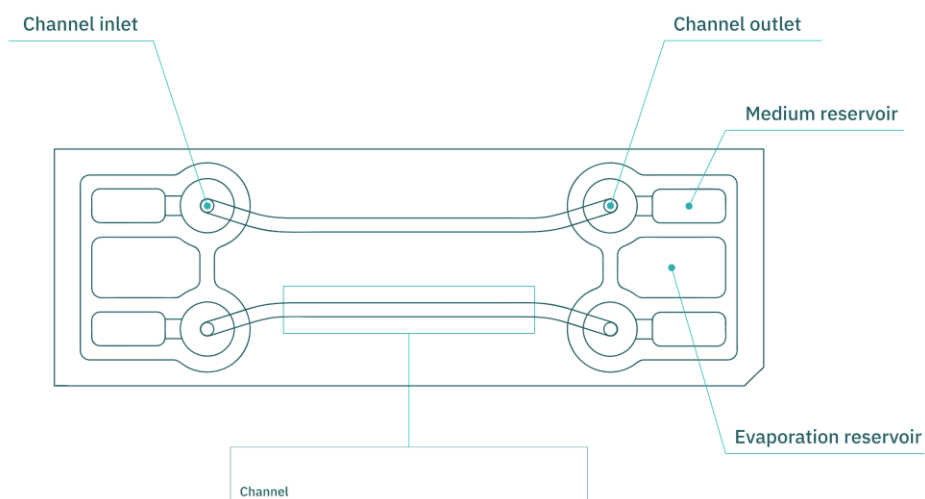

Content

The box contains **10 Be-Flow** chips that are **individually packaged**. Each chip undergoes a sterilization process before sending the chip to the final user. It can be stored in **dry places** that are **not exposed to direct sunlight** at room temperature (**15-25°C**).

Filling and handling

Before seeding, prewarm the device in the incubator overnight to avoid the appearance of air bubbles.

When filling the channels up, **place the tip of the pipette completely vertical** into the channel's inlet pinhole. Inject the liquid with a **continuous and constant flow** to avoid backward flow.

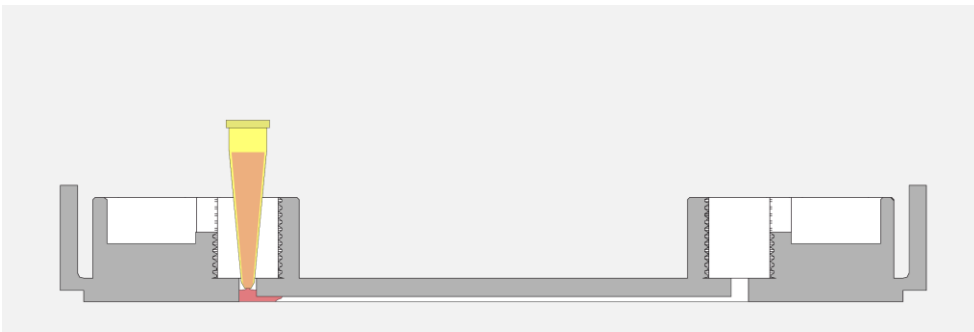

Use the **lateral holders** for easy and safe handling.

Coating

Depending on the cell type(s), one or two different coatings may be necessary.

The following protocol is applicable for channel **coating**, **washing**, **staining**, **cell extraction** and **medium refreshing**.

Channel coating

1. Fill the channel volume up with the **coating solution** by pipetting through the pinhole and incubate at manufacturer's conditions.

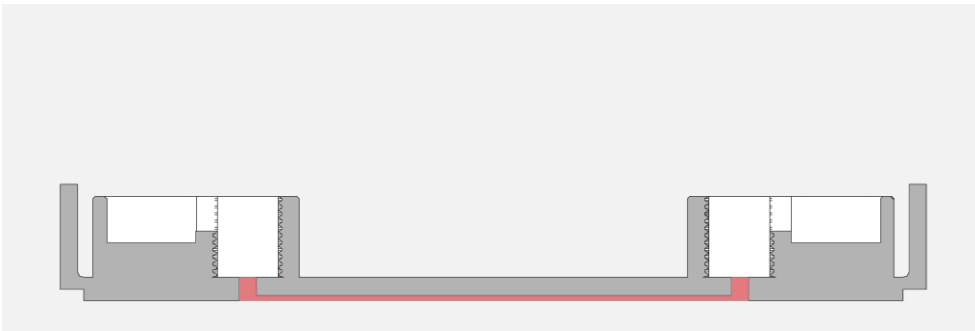

Note: Another way to proceed is to **pipette the solution into the inlet well** and **let the liquid flow** by itself through the channel **until it reaches the outlet well**.

2. Remove the solution from the reservoirs and inlet/outlet wells and **wash the channel** (if needed) by adding the recommended dilution buffer into the inlet well. Remove it at the outlet well with the pipette. **Repeat** this step **as many times as needed**.

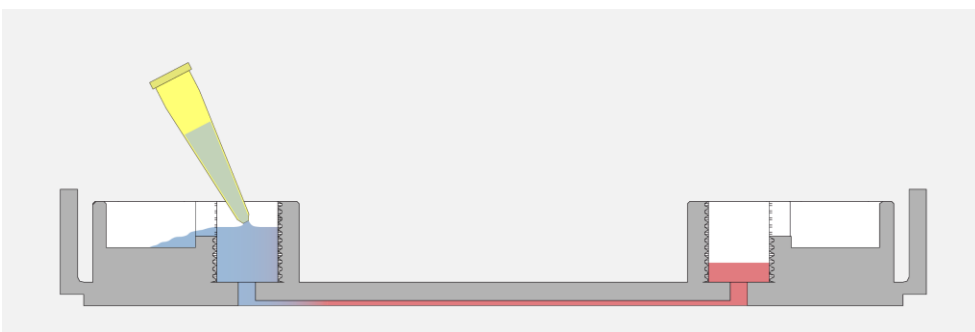

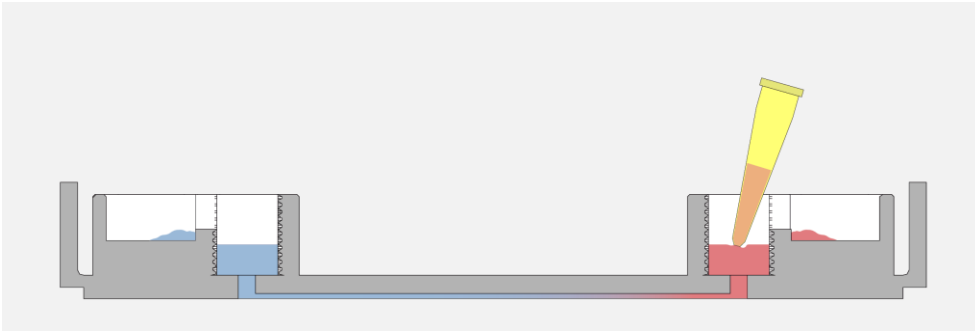

Tip: You may **tilt the device** manually in order to ease the dilution buffer flow **several times** from one reservoir to another before you remove it.

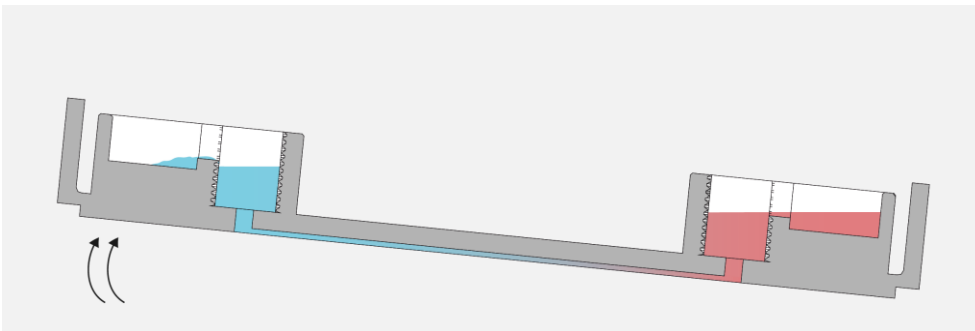

3. Aspirate the dilution buffer completely before seeding.

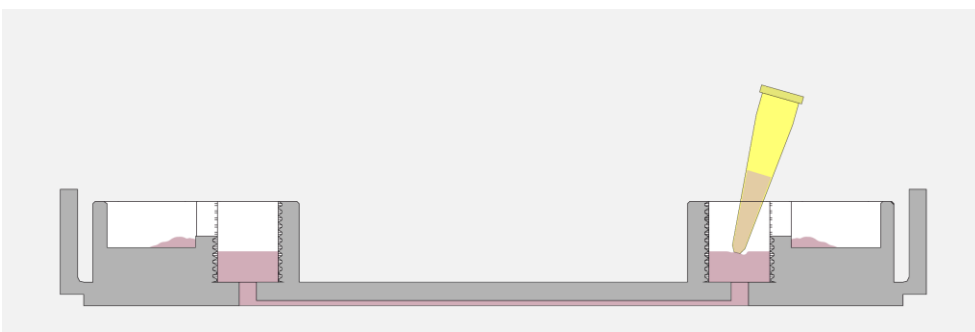

Important: Note that the channels should never dry up. Take incubation times into account and use the evaporation reservoirs as long as possible.

Cell culture

1. Trypsinize and count cells as usual. Cell concentration will vary with **cell type** and **channel dimensions**. For **2D culture**, it is recommended to seed the **cell concentration needed** to obtain a **monolayer**.

2. Fill the lower channel up with the **exact volume** of the channel by pipetting through the pinhole.

Important: Adding the correct volume into the channel helps save and concentrate the cells. Thus, it promotes a faster creation of the monolayer along the channel.

3. Cover the inlets, and incubate until the cells attach (time may vary depending on the cell type).

4. After cell attachment, **add more medium** to the medium reservoirs and PBS or water to the evaporation reservoirs. **Cover and incubate** until needed.

5. Refresh the medium according to cellular requirements.

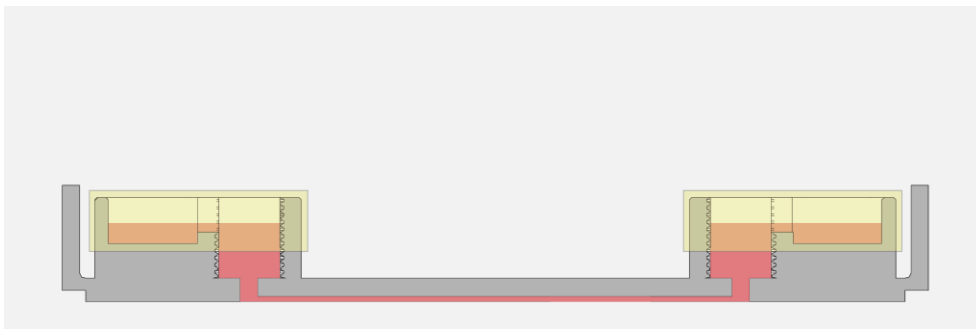

For optimal seeding inside the channel, we recommend a constant renewal of the medium once the cells have adhered to the surface of the device (from two to six hours after seeding).

3*. When seeding a monolayer **on the top (ceiling) of the channel**, in **step 3 flip the chip downwards** during incubation until cell attachment.

4*. After cell attachment, **flip the chip upwards** again.

5*. Then, for the bottom cell seeding, **add the channel volume of medium plus cells** (at the desired concentration) in the inlet well and aspirate with a micropipette very gently **from the outlet well**.

- Stop aspirating before air enters the channel.
- Remember, once the cells are in the channel, it should never be emptied.

6. Cover the inlets and **incubate** cell attachment. Continue with **step 4**.

Important: Do **not remove the medium inside the channel** during medium refreshing. This will prevent the entrance of air bubbles. Thus, when removing the solution, **place the tip of the pipette away from the pinhole** to avoid emptying the channel.

When using Be-Flow in long lasting experiments we recommend using a flow control system of your choosing (rocker, syringe, peristaltic, pressure-based..) to avoid the depletion of nutrients in the media inside the channel.

Flow set up

Before setting the flow up:

- **Sterilize and prewarm** the tubes and the fluidic elements overnight at 37°C.
- Set the system in a **laminar flow cabinet**.
- **Cells must be well adhered** to the surface before mounting the perfusion system. Beonchip recommends at least 24h after seeding until full monolayer is formed.
- The channels and inlet/outlet wells should **never be depleted of culture medium**.
- Both inlets and outlets are designed to be for **screw connectors (1/4" - 28)**.

For more information regarding connecting a microfluidic flow system check our website. [Link](#).

Connecting a perfusion system

9. Remove the medium from the reservoirs.

10. Screw the outlet connector and ensure that the tube is perfectly fixed.

Remove the displaced medium from the reservoir.

11. Prime the tube that will **connect to the inlet** before assembling. This will **prevent air bubbles** from entering the device.

12. Screw the inlet connector and remove the displaced medium from the reservoirs.

13. Once the system is closed, **switch the flow on**.

Check that there are **no leaks** in the system by leaving the pump **running for a couple of minutes** before placing the device in the incubator. Medium reservoirs will be filled up if the connections are not completely closed.

See YouTube video: [Be-Flow: Coating and Cell Culture](#).

Culture models

The interaction between hemodynamics and vascular endothelium is an important factor to consider in cardiovascular function. Vascular endothelial cells from the inner wall of arterial vessels are exposed to the blood flow which acts on the endothelium surface as a tangential force (shear stress). Under mechanical stimuli, cells can adjust several biological responses through mechanotransduction processes. The Be-Flow design consists of two independent channels. Each channel has an inlet and outlet reservoir that can be connected with a flow system, emulating the frame of a blood vessel. Seeding endothelial cells on top of an ECM coated surface, that meet cell type specific needs for growth and adhesion, makes it possible to recreate a dynamic environment under different, physiological and pathological, flow rates.

Find several of the most frequently used culture models on the Be-Flow below.

- (1). Seeding a monolayer** on the channel surface.
- (2). Seeding a monolayer on the bottom and top** channel surfaces.
- (3). Perfuse immune system cells, CTC's or bacteria** and explore their interaction with the culture.
- (4). Seeding a double layer** on the channel surface.

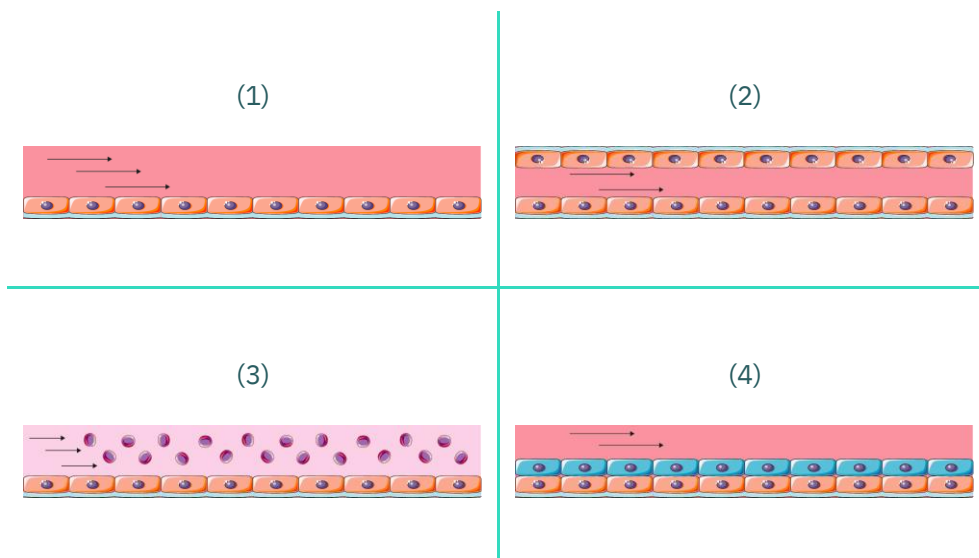

Contact and support

Our team of technicians will be happy to help you with any questions about the operation of our devices. **You can contact us on the following channels:**

info@beonchip.com

+34 655 16 16 91

www.beonchip.com

Beonchip S.L.
Campus Río Ebro
Mariano Esquillor s/n
Edificio CEMINEM
50018, Zaragoza, Spain

